

## A Series Pallet Stacker Mini Range-Double Column

Distinguishing mark	HANGCHA GROUP CO.,LTD.							
	1.1	1.2	CDD10-AMC1-SZ	CDD10-AMC1-B/SZ	CDD12-AMC1-SZ	CDD12-AMC1-B/SZ		
1.1	Manufacturer							
1.2	Manufacturer's type designation							
1.4	Operator type: hand, pedestrian, standing, seated, order-picker	Pedestrian	Pedestrian	Pedestrian	Pedestrian			
1.5	Rated capacity/rated load	Q (kg)	1000	1000	1200	1200		
1.6	Load centre distance	c (mm)	600	600	600	600		
1.9	Wheelbase	y (mm)	1273	1273	1273	1273		
2.1	Service Weight(Including battery)	kg	744	744	744	744		
Weight	Battery weight	kg	66	66	66	66		
Tyres, chassis	3.1	Tyres: solid rubber, superelastic, pneumatic, polyurethane	PU	PU	PU	PU		
	3.2	Tyre size, front	Φ250x80	Φ250x80	Φ250x80	Φ250x80		
	3.3	Tyre size, rear	Φ85x70	Φ85x70	Φ85x70	Φ85x70		
	3.4	Additional wheel (dimensions)	Φ125x50	Φ125x50	Φ125x50	Φ125x50		
	3.5	Wheels, number front / rear (x = driven wheels)	1x+1/4	1x+1/4	1x+1/4	1x+1/4		
	3.6	Tread, front	b10 (mm)	520	520	520		
	3.7	Tread, rear	b11 (mm)	390	1000/1170/1370	390	1000/1170/1370	
Dimensions	4.4	Lift	h3 (mm)	3000	3000	3000		
	4.9	Height drawbar in driving position min./max.	h14 (mm)	720/1220	720/1220	720/1220	720/1220	
	4.15	Fork height, lowered	h13 (mm)	85	50	85	50	
	4.19	Overall length (folded pedal)	l1 (mm)	1800	1836	1800	1836	
	4.21	Overall width	b1 (mm)	800	1100/1270/1470	800	1100/1270/1470	
	4.22	Fork dimensions	s/e/l (mm)	60/170/1150	35/100/1070	60/170/1150	35/100/1070	
	4.25	Distance between fork-arms	b5 (mm)	560	210-790	560	210-790	
	4.32	Ground clearance, centre of wheelbase	m2 (mm)	35	35	35	35	
	4.34.1	Aisle width for pallets 1000 x 1200 crossways	Ast (mm)	2016 <sup>1)</sup>	1901 <sup>2)</sup>	2016 <sup>1)</sup>	1901 <sup>2)</sup>	
	4.34.2	Aisle width for pallets 800 x 1200 lengthways	Ast (mm)	2066 <sup>3)</sup>	2101 <sup>4)</sup>	2066 <sup>3)</sup>	2101 <sup>4)</sup>	
	4.35	Turning radius	Wa (mm)	1466	1466	1466	1466	
	Performance data	5.1	Travel speed, laden/unladen	km/h	4.0/4.5	4.0/4.5	4.0/4.5	4.0/4.5
		5.2	Lift speed, laden/unladen	m/s	0.120/0.190	0.120/0.190	0.120/0.190	0.120/0.190
5.3		Lowering speed, laden/unladen	m/s	0.140/0.150	0.140/0.150	0.140/0.150	0.140/0.150	
5.8		Max Gradeability, laden/unladen	%	6/10	6/10	5/10	5/10	
Electric engine	6.1	Drive motor rating S2 60 min	kW	0.7	0.7	0.7	0.7	
	6.2	Lift motor rating at S3 15%	kW	2.2	2.2	2.2	2.2	
	6.4	Battery voltage, rated capacity	V/Ah	2x12/106	2x12/106	2x12/106	2x12/106	
	8.1	Type of drive control	DC	DC	DC	DC		
	9.1	Manufacturer	Curtis	Curtis	Curtis	Curtis		

Note: 1) VDI 2198: +282mm 2) VDI 2198: +166mm 3) VDI 2198: +409mm 4) VDI 2198: +156mm

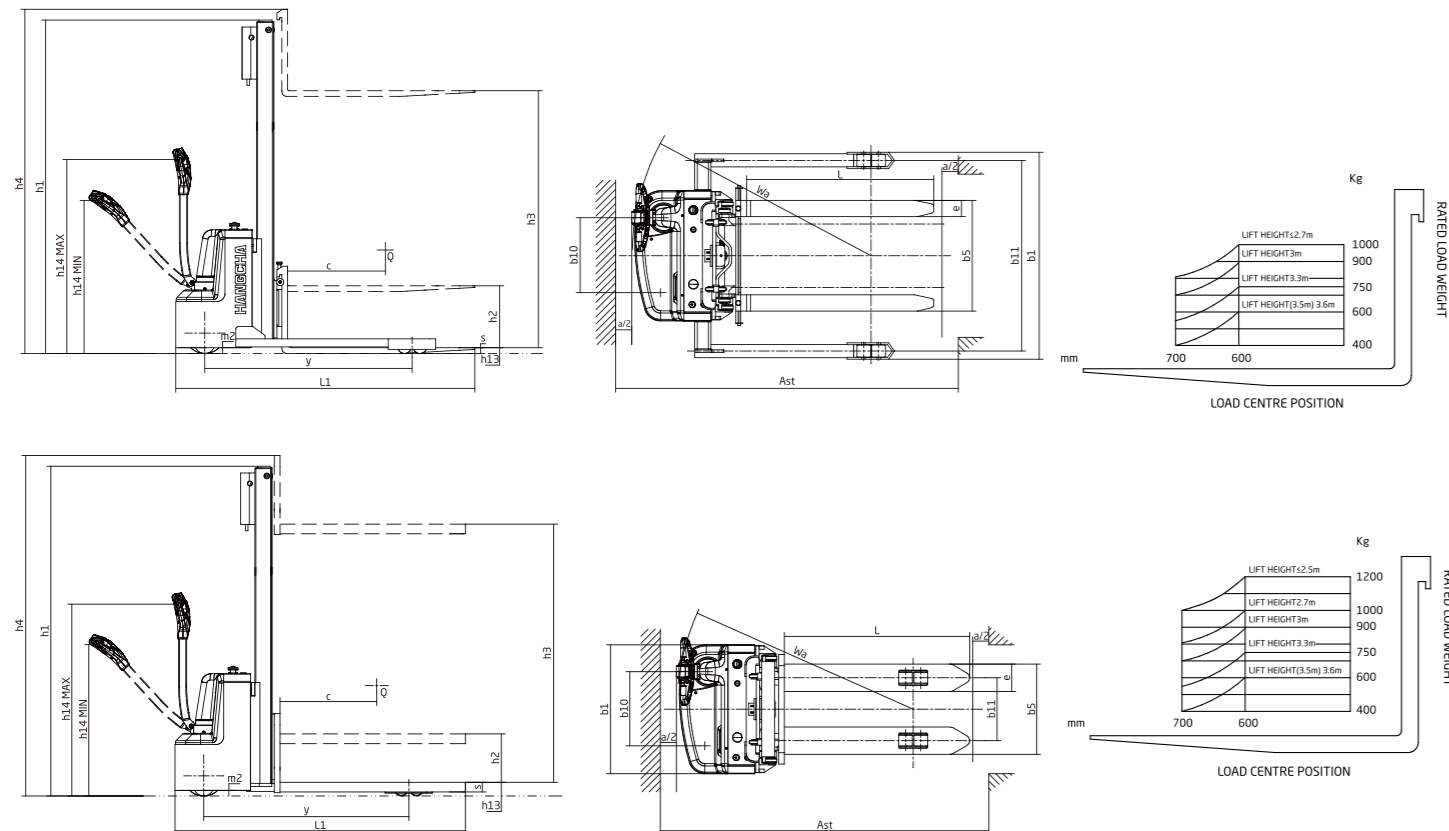

## 1.0/1.2t Mini Range Pallet Stacker Double Column Specification:

Mast Type	Max Lifting Height h3	Max. fork height (h3+h13)	Lowered Height h1	Extended Height h4	Free lift	Load Capacity at 600mm	
						1.0t	1.2t
Single cylinder duplex mast	mm	mm	mm	mm	mm	Kg	Kg
	2000	2085/2050	1545	2545	0	1000	1200
	2500	2585/2550	1795	3045	0	1000	1200
	2700	2785/2750	1895	3245	0	1000	1000
	3000	3085/3050	2045	3545	0	900	900
	3300	3385/3350	2195	3845	0	750	750
	3500	3585/3550	2295	4045	0	600	600
	3600	3685/3650	2345	4145	0	600	600



## A Series Pallet Stacker Mini Range Double Column

with capacities of 1,000 to 1,200kg



**HANGCHA**

**ZHEJIANG HANGCHA IMP. & EXP. CO., LTD.**

Factory site: No. 88, Donghuan Rd., Lin'an Economic Development Zone, Zhejiang, China (311305)

Tel: +86-571-88926735 88926755  
Fax: +86-571-88132890 88926789

sales@hcforklift.com  
www.hcforklift.com



ISO14001:2004



ISO9001:2008



HANGCHA trucks conform to the European Safety Requirements.

HANGCHA GROUP CO., LTD. reserves the right to make any changes without notice concerning colors, equipment or specifications detailed in this brochure, or to discontinue individual models. The colors of trucks, delivered may differ slightly from those in brochures.

Printed in China 2016/05/EN



The World of Hangcha



**HANGCHA**



# A Series Mini Range Pallet Stacker Double Column

The A series mini range pallet stacker (double column) has been engineered to be both powerful and flexible to meet the requirements of many demanding applications. Whether it's supermarket work, delivery service, stock replenishment or heavy manufacturing, it has the strength and durability to minimise your total cost of ownership.

## Easy/ Efficiency/ Economy

### Appearance

- / A series mini range pallet stacker (double column) applied professional industrial design, stream lines, and compact, and fully ergonomic consideration, in line with the latest design trends.
- / Applied steel stamping and injection molding processes, which is robust, durable, and also environmental compliance.



## High Performance

- / Rated capacity 1000/1200kg, meet the needs of the majority of customers.
- / Powered by traction motor not only has good acceleration and perfect performance, but also low heat.
- / Latest CURTIS permanent magnet control system, precise and smooth.
- / Regenerative braking for battery recovery during travel speed reduction, anti-slope on gradient.
- / All key parts such as tiller, switches, connectors, battery indicator and hour meter all adopt the famous brand.

## Comfort

- / Built-in charger and maintenance free gel battery adopted to provide convenient usage.
- / The compact body and semicircular design provide an ideal operation in limited space.

## Reliability

- / High strength steel frame structure chassis provide larger residual load capability and longer working life.
- / 4-pivot design provide reasonable load distribution, and the good wheel grip ensuring excellent stability.
- / Imported waterproof connectors, all wires and cables are protected, greatly improve the reliability of the electric system.
- / Top quality hydraulic power unit applied to provide low noise, low vibration, smooth lifting and landing reliable operation.
- / The hydraulic unit and the chassis adopt flexible connection, can absorb vibration from the uneven road.
- / Punch formed forks to provide more strength and tip guide to provide higher efficient operation.

## Safety

- / Three braking system of regenerative braking, reverse current braking, parking brake, insures the safe operation.
- / Anti-slope on gradient can keep the safety.
- / The emergency button on the tiller head can effectively avoid the harm to the driver.
- / Soft landing system applied to protect loads from damaging effectively.

## Maintenance

- / Integrated battery indicator, hour meter and self-diagnostic instrument.
- / All shafts installed lubricated shaft sleeve and oil cup, provide convenient maintenance and long service life.
- / Dismantle the additional wheel don't need to lift the truck.

## Standard specification

- / Permanent magnet drive motor
- / CURTIS permanent magnet controller
- / Hydraulic unit
- / Emergency switch
- / Multi-function battery indicator
- / PU wheel
- / 1150mm fork length
- / 560mm outside fork width
- / Tiller
- / Horn
- / Maintenance free battery
- / Internal charger

## Options

- / Mast lift height:2000-3600mm
- / 1220/1400mm fork length
- / 680mm outside fork width
- / Cold store protection(-30 C)
- / Load backrest



Fully opened hood, easy accessibility of all components, is easy for service



Optimized designing structure to offer a good visibility and easy entrance to the pallet



Built-in charger and maintenance free gel battery, you don't need to worry about them



Simple and beautiful tiller designed to improve the operator's driving comfort